

Deep vibratory compaction of granular soils

K. Rainer Massarsch
Geo Engineering AB
Ferievägen 25, S-161 51 Bromma, Sweden
<Rainer.Massarsch@geo.se >

and

Bengt H. Fellenius
Bengt Fellenius Consultants Inc.
1905 Alexander Street, Calgary, Alberta, T2G 4J3
<Bengt@Fellenius.net>

Massarsch, K.R. and Fellenius, B.H., 2005.
Deep vibratory compaction of granular soils.
Chapter 19 in Ground Improvement-Case
Histories, Elsevier publishers, B. Indranatna
and C. Jian, Editors, pp. 633 - 658.

Deep Vibratory Compaction of Granular Soils

K. Rainer Massarsch

Geo Engineering AB, Ferievägen 25, SE 168 41 Bromma, Sweden

Bengt H. Fellenius

Bengt Fellenius Consultants Inc., 1905 Alexander Street SE, Calgary, Alberta, Canada

ABSTRACT

Planning and execution of deep vibratory compaction of natural and man-made fills requires recognition of fundamental soil aspects, such as the compactability of soils. Design is usually based on cone penetration tests and carried out with equipment specially developed for deep vibratory compaction, in particular, using variable frequency vibrators. The features of different, purpose-built types of compaction probes are described and the most important factors governing the compaction process are presented, such as vibration frequency—an important parameter as it influences probe penetration—and can enhance compaction by means of resonance effects during the compaction phase. Vibratory compaction generates lateral stresses, which result in a permanent increase of the horizontal earth pressure and overconsolidation. The practical importance of these effects is discussed.

1. INTRODUCTION

Where granular soils have inadequate compressibility or strength, resorting to soil compaction is usually viable and economical, and applicable to both shallow and deep foundations. Compaction is particularly useful where the foundations will be subjected to dynamic and cyclic loading. By compaction is meant densification by dynamic methods, which, depending on the manner of imparting the energy to the soil, can be divided into two main categories: impact compaction and vibratory compaction. The methods and their practical applications are described extensively in the geotechnical literature, e.g., Massarsch (1991; 1999), Mitchell (1981) and Schlosser (1999).

Vibratory compaction methods have found wide acceptance, and numerous case histories have been described in the geotechnical literature, illustrating their practical applications. However, only limited information is available on the fundamental aspects of vibratory compaction that govern the planning, execution, and evaluation of vibratory compaction projects. This paper discusses, based on the evaluation of numerous case histories, different aspects of deep vibratory compaction with emphasis placed on field execution and monitoring. The effect on soil strength and stiffness, as well as the resulting change of stress conditions in coarse-grained soils are addressed, as these are of importance for geotechnical design of the foundations to be placed on the compacted soil.

In the recent past, vibratory compaction methods have become more competitive due to several important developments, as follows,

- powerful construction equipment (e.g. vibrators and cranes) has become available, making it possible to achieve higher compaction and to reach deeper into the soil,
- more reliable geotechnical field investigation tools, such as electric cone penetrometers (CPT), piezocones (CPTU), seismic cones (SCPT), dilatometers (DMT), and pressuremeters (PMT),
- improved understanding of the static, dynamic, and cyclic behaviour of soils, which has made it possible to model deformation characteristics of soils more accurately,
- more sophisticated analytical and numerical methods for predicting settlements, soil-structure interaction, or the dynamic response of soil deposits during an earthquake,
- increase in the reliability of electronic equipment for use in rough site conditions, important for monitoring and documenting the compaction process.

The planning of vibratory compaction requires geotechnical competence and careful planning on the part of the design engineer. Similarly, the contractor needs to possess experience and suitable equipment to carry out deep soil compaction. It is common practice to award soil compaction projects to the lowest bidder. However, after completion of a project, this may not always turn out to be the optimal solution, if the required compaction is not achieved, or the duration of work is significantly exceeded. The selection of the most suitable compaction process depends on a variety of factors: soil conditions, required degree of compaction, type of structure to be supported, maximum depths of compaction, site-specific considerations such as sensitivity of adjacent structures or installations, available time for completion of the project, access to equipment and material, and, not least, the competence of contractor. Moreover, it is paramount for all types of soil compaction projects that a high degree of quality control and site supervision is maintained.

2. COMPACTABILITY OF SOILS

One of the most important questions to be answered by the geotechnical engineer is whether or not—and to which degree—a soil deposit can be improved by dynamic methods (vibratory or impact compaction). Mitchell (1982) identified suitable soil types according to grain size distribution and indicated that most coarse-grained soils with a "fines content" (amount of particles smaller than 0.06 mm, Sieve #200) below 10 % can be compacted by vibratory and impact methods. However, compaction assessment based on grain-size curves from sieve analysis has the disadvantage that, in order to obtain a realistic picture of the geotechnical conditions, a large number of soil samples and sieve analyses is required—larger than what is usually considered justifiable for a routine foundation project. Going back to a site in order to obtain additional samples is impractical due to time constraints. Moreover, obtaining representative soil samples may prove to be difficult and costly because the soils at such sites are usually loose and water-saturated. Moreover, soil lenses and layers of importance for the assessment may not be evident from the inspection of soil samples obtained intermittently. It is therefore preferable to base the assessment of compactability on results of the CPT, as these

measurements present continuous soil profiles reflecting variations in soil strength and compressibility, and, in the case of the piezocone, also variations in hydraulic conductivity of the soil.

Massarsch (1991) proposed that the compactability of soils can be classified as “compactable”, “marginally compactable”, and “not compactable”. Figure 1 presents a conventional soil classification chart with the friction ratio along the abscissa and the cone resistance (q_t) along the ordinate. (It should be noted that the diagram assumes homogeneous soil conditions. Layers of silt and clay can inhibit the dissipation of excess pore pressures and, therefore, reduce the compaction effectiveness).

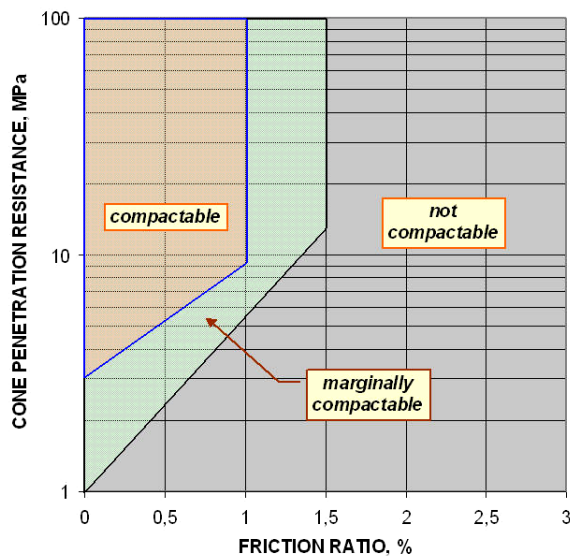

Fig. 1. Soil classification for deep compaction based on CPT data. After Massarsch, (1991).

Figure 2 shows the same compaction boundaries where the cone stress (cone resistance) is shown as a function of the sleeve friction (Eslami and Fellenius, 1995; 1997; and Fellenius and Eslami, 2000). As the ranges of cone stress and sleeve friction applicable to compaction projects are relatively narrow, the usual logarithmic-scale compression of the axes can be dispensed with and Fig. 2 be shown in linear scale axes.

Compaction criteria are frequently expressed in terms of cone stress unadjusted for overburden stress (depth). However, similar to the depth adjustment employed for SPT data, it is preferable to express CPT compaction criteria in terms of a cone stress value adjusted with respect to the mean effective stress. Expressing compaction specifications in terms of the stress-adjusted cone stress will better reflect uniformity of soil density, or lack of uniformity, as opposed to using the unadjusted cone stress. If the cone data are not adjusted according to the stress level (depth), applying a specific value of cone stress as a compaction criterion throughout a soil deposit may lead to the upper layers of the deposit becoming overcompacted while the deeper layers remain loose. When this aspect is not recognized, the result is excessive compaction costs, undesirable loss of ground, and a soil deposit that is not uniformly compacted.

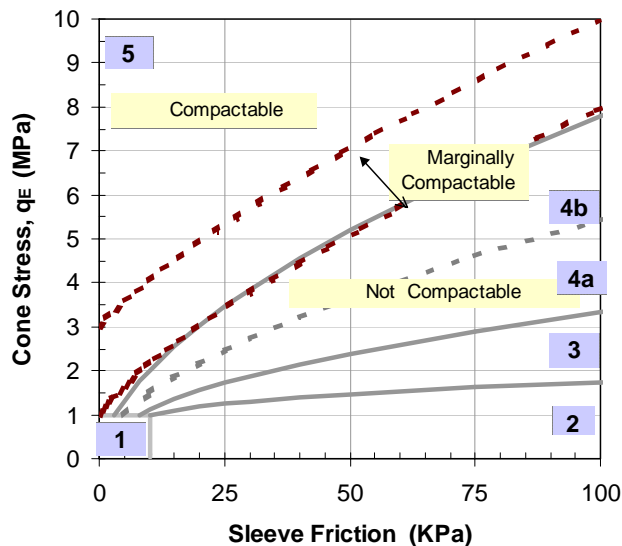

Fig. 2. Soil classification for deep compaction based on the Eslami-Fellenius chart with boundaries from Fig. 1.

3. EXECUTION OF DEEP VIBRATORY COMPACTION

The vibratory compaction process consists of the following three elements, which need to be adapted to the site conditions and densification requirements, in order to achieve optimal performance:

- Compaction equipment: compaction probe, vibrator and powerpack, and base machine.
- Compaction process: compaction point grid and spacing, vibration frequency, and mode of probe insertion and extraction.
- Process control and monitoring: production control and verification of densification effect.

The main elements of vibratory compaction equipment are shown in Fig. 3.

3.1. Compaction Equipment

The compaction equipment includes the following components: vibrator with powerpack, compaction probe and base machine (carrier).

Vibrator Characteristics

Modern vibrators are hydraulically driven and the vibration frequency can be varied during operation. The vertical oscillation of the vibrator is generated by counter-rotating eccentric masses.

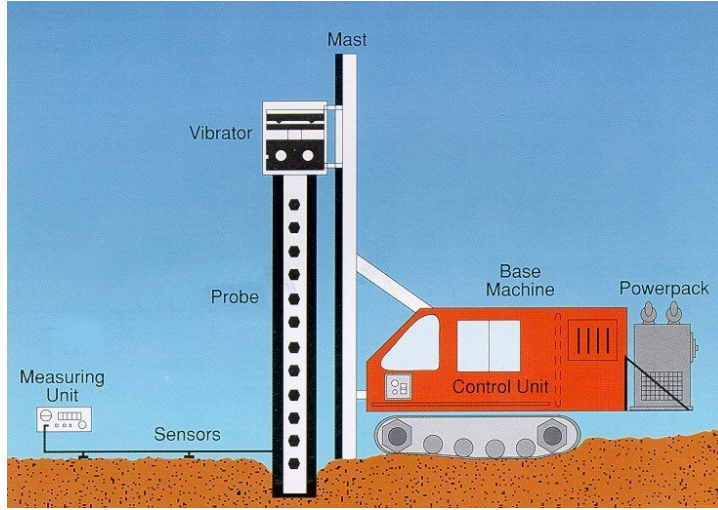

Fig. 3. Main elements of vibratory compaction equipment (resonance compaction system).

The static moment M , which is an important parameter for vibrator applications, is the product of the mass of the eccentric weights G and the distance r of their centre of gravity to the rotation axis,

$$M = G \cdot r \quad (0.1)$$

The static moment is thus not affected by the vibration frequency f . The peak centrifugal force F_v acting in the vertical direction, depends on the static moment M and on the circular frequency ϖ ($2\pi f$) of the eccentric masses,

$$F_v = M \varpi^2 \quad (0.2)$$

Figure 4 shows the relationship between the vibration frequency f and the centrifugal force F_v for different values of the static moment.

The most important factor for soil compaction is the displacement amplitude S (double amplitude). For a free-hanging vibrator (including vibrating mass, compaction probe and clamp), before insertion of the probe in the ground, the vertical displacement amplitude S_0 (double amplitude) can be determined from

$$S_0 = 2s = 2 \frac{M}{G_D} \quad (0.3)$$

The “total dynamic mass” G_D ($G_{\text{VIBRATOR}} + G_{\text{CLAMP}} + G_{\text{PROBE}}$) is the sum of all masses which need to be excited by vibratory action. It should be noted that both the static moment M and the displacement amplitude S_0 are independent of vibration frequency. In order to obtain maximum displacement amplitude, which is the key parameter for soil compaction, the dynamic mass G_D should be kept as small as possible. This can, for instance, be achieved by creating openings in the compaction probe, as will be discussed below.

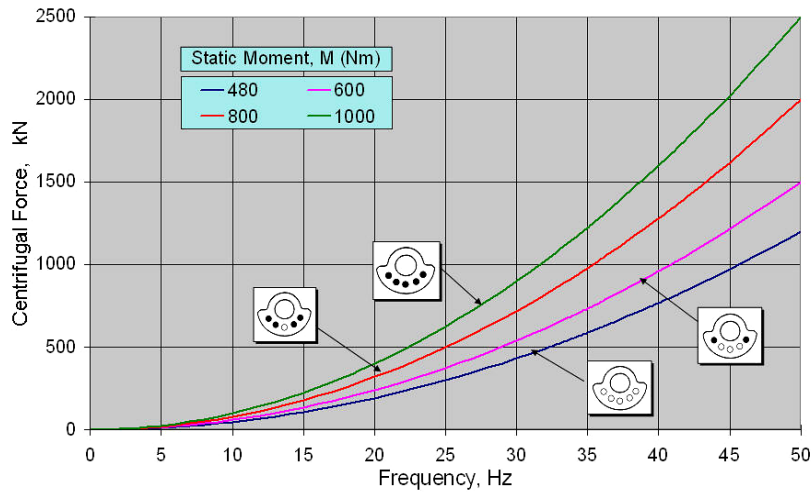

Fig. 4. Centrifugal force generated by variable frequency vibrator as a function of the operating frequency for different values of the static moment.

The displacement amplitude S_D is defined as the difference between the ground vibration amplitude S_G and the probe vibration amplitude S_p . In the case of “resonance” during vibratory compaction, the compaction probe and the soil are oscillating “in phase”, and the relative displacement amplitude between the probe and the soil is small, resulting in efficient transfer of the vibrator energy to the surrounding soil.

Vibrator and Powerpack

The first vibrators for pile driving were developed some 60 years ago in Russia and have since been used extensively on foundation projects world-wide. Conventional vibrators can change the operating frequency by throttling the hydraulic pressure on the powerpack. In order to avoid a loss of hydraulic power when the frequency is reduced, a pump system was developed which maintains the power of the vibrator independently of the operating frequency. The pumps can be electronically controlled and the operating frequency of the vibrator can be adjusted at all stages of the compaction process. During the past decade, very powerful vibrators have been developed for foundation applications, such as pile and sheet pile driving and soil compaction. These vibrators are hydraulically driven, which allows continuous variation of the vibrator frequency during operation. Moreover, modern vibrators can generate a centrifugal force of up to 4,000 kN (400 tons), and the maximum displacement amplitude can exceed 30 mm. These enhancements in vibrator performance have opened new applications to the vibratory driving technique, and in particular to soil compaction. Figure 5 shows the operating principles of a vibrator with variable frequency and variable eccentric moment (“static moment”), with eight eccentric masses, arranged at two rows of four masses at separate rotation levels. During any stage of vibrator operation, the position of the lower row of masses can be changed relative to that of the upper row, thereby affecting the static moment and the displacement amplitude. This makes it possible to start up the vibrator to the desired frequency without vibration. Once the operating frequency has been reached, the eccentric moment is gradually increased to the desired intensity of vibrations.

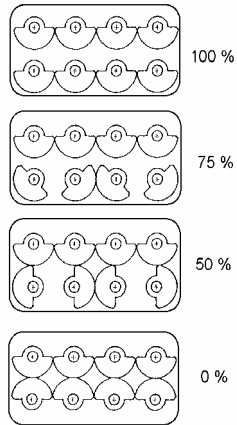

Fig. 5. Operating principle of vibrator with dual rows of eccentric masses, allowing variation of the static moment (displacement amplitude).

Compaction Probe

The compaction probe is an important component of the vibratory compaction system. The probe is inserted in the ground with the aid of a heavy, vertically oscillating vibrator, attached to its upper end. Different types of compaction probes have been developed, ranging from conventional pile (H-beam), tubes, or sheet pile profiles, to more sophisticated, purpose-built probes (Terra probe, Vibro-rod, and Y-probe), Fig. 6.

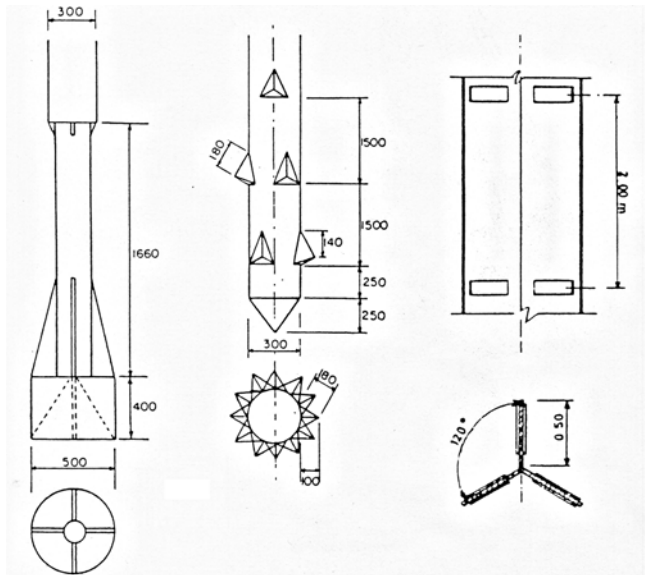

Fig. 6. Examples of compaction probes (from left to right: Terra probe, Vibro-rod and Y-probe).

The Vibro-Rod was initially developed in Japan, as a slender compaction tool, provided with short ribs. The Y-probe consists of three steel blades, welded together at an angle of 120 degrees. Extensive field tests have shown that the Y-shape arrangement is most efficient in transferring the vibration energy from the probe to the surrounding soil, as it avoids the “arching effects” that occur at a 90-degree arrangement.

The so-called VibroWing is a further improvement of the Vibro-rod, and was developed in Sweden. It consist of an up to 15 m long steel rod with about 0.8 m to 1,0 m long radial plates (wings), spaced approximately 0.5 m apart. The vibratory hammer is usually operated from a piling rig, Fig. 7. A limitation of the VibroWing method is that in well-compacted soils, extraction of the probe can become difficult.

Extensive field tests and project experience have demonstrated that a double Y-shape is the most efficient geometry of the compaction probe. The area of influence adjacent to the compaction probe is increased and close to rectangular in shape, as opposed to the circular influence area in the case of rods or Y-shaped probes. The double Y-shaped is shown in Fig. 8 is an essential element of the resonance compaction system, which will be discussed below. The probe is provided with openings in order to reduce the weight of the probe and to increase the contact with the soil layers to be compacted. Reducing the weight and stiffness of the probe further increases the transfer of energy to the surrounding soil. The lighter probe achieves larger displacement amplitude during vibration and thus more efficient compaction, compared to a massive probe of the same size.



a) Vibro Wing machine

b) Vibro Wing rod

Fig. 7. VibroWing equipment and compaction probe.



a) MRC compaction equipment

b) MRC compaction probe

Fig. 8. Flexible compaction probe with openings to enhance energy transfer from vibrator to ground.

Compaction probes can also be provided with water jetting equipment in order to facilitate penetration into stiff soil layers. Water jetting has also beneficial effects on soil compaction, especially in unsaturated or partially water-saturated soil deposits.

3.2. Compaction Process

The compaction process is an important element of deep vibratory compaction and can influence the technical and economical results significantly. However, in practice, this aspect is not appreciated. The compaction process requires that the following parameters are chosen:

- compaction point spacing,
- vibration frequency,
- probe penetration and extraction, and
- duration of compaction.

Compaction Point Spacing

Normally, a triangular pattern of compaction points is chosen. However, by using a double Y-shaped compaction probe, which has an almost rectangular influence area, a rectangular pattern of compaction grid points is possible, which reduces the number of required compaction points by approximately 13 percent. It should be noted that the spacing between compaction points needs to be chosen also with respect to practical considerations, such as the overall geometry of the site, the reach of the compaction machine, and the number of compaction passes. It is generally advantageous to perform compaction in two passes, as this will result in more homogeneous soil densification.

This aspect is of particular importance when impervious layers of silt or clay exist in the soil deposit to be compacted. Such soil deposits are usually prone to augment liquefaction in the intermediate soil layers, as the impervious layers prevent or reduce the vertical flow of water and thus affect the dissipation of excess pore water pressure during earthquakes. A similar situation occurs during vibratory compaction of loose, water-saturated soil deposits and reduces compaction efficiency. However, if compaction is carried out in two passes, the probe will create drainage channels during the first pass, resulting in more efficient compaction during the second pass.

What spacing between compaction points to assign depends on several factors, such as the geotechnical site conditions prior to compaction, the required degree of compaction, the size of the compaction probe (influence area), and the capacity of the vibrator. It is generally advantageous to use a smaller spacing with a shorter duration of compaction rather than a larger spacing with longer duration. This will result in more homogeneous compaction of the soil deposit. The spacing between compaction points ranges typically between 1.5 and 5 m.

Vibration Frequency

The vibration frequency is an important parameter of vibratory soil compaction and should be chosen with care. During insertion and extraction, it is desirable that the shaft resistance along the probe is as small as possible. This is achieved by using a high frequency—higher than about 30 Hz. Ground vibrations are then low and most of the vibration energy is converted into heat along the shaft of the probe and little energy reaches the soil body. In contrast, during the compaction phase, the objective is to transfer the energy generated by the vibrator along the vertically oscillating compaction probe to the surrounding soil as efficiently as possible, which is achieved when the probe is vibrated in resonance with the soil—usually about 15 to 20 Hz. Resonance between the vibrator-probe-ground system, leads to amplification of the ground vibrations, as the probe and soil move “in phase” with little or no relative displacements occurring—achieving efficient transfer of the vibration energy to the ground. It should be noted that in this state, probe penetration will become slow or stop completely. Figure 9 shows the vertical vibration velocity on the ground surface, measured by a vibration sensor (geophone) at a distance of 4 m from the compaction probe.

The resonance frequency depends on several factors, such as the mass of the vibrator, the length and size of the compaction probe, and the shear wave velocity of the soil. The resonance frequency will increase with increasing shear wave velocity, reflecting a change of soil stiffness and soil strength, Massarsch (1995).

Figure 10 shows measurements during different phases of soil compaction, where the hydraulic pressure in the vibrator system, the operating frequency, the depth of probe penetration, and the vertical vibration velocity on the ground measured at a distance of 4 m are shown.

When the vibrator frequency is tuned to the resonance frequency of the vibrator-probe-ground system, the probe oscillates in phase with the adjacent soil layers. Ground vibrations increase markedly, while the required compaction energy (hydraulic pressure) is low. At higher frequencies, the probe oscillates relative to the adjacent soil layers and ground vibrations decrease, while the required hydraulic pressure increases significantly.

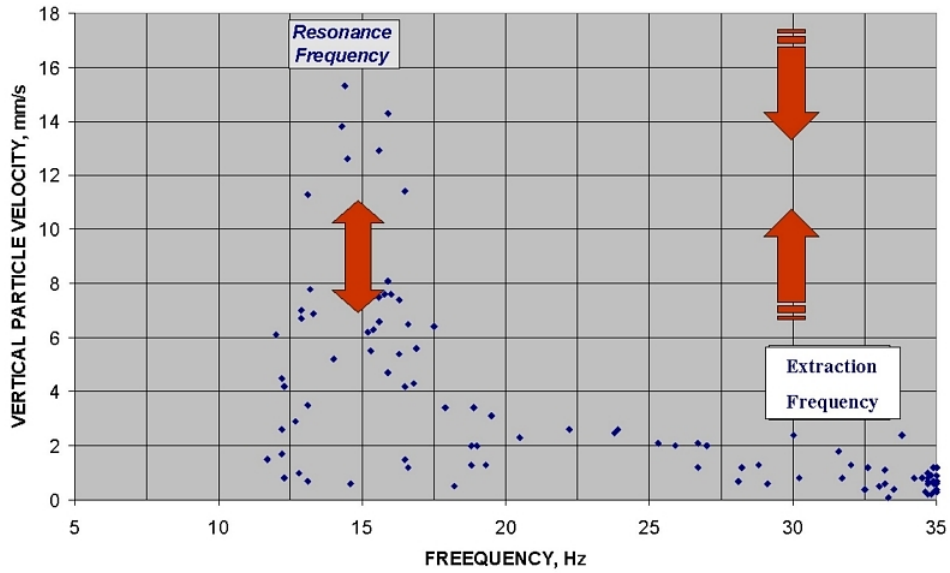

Fig. 9. Ground vibration velocity during probe penetration and compaction measured at 4m distance from the compaction probe.

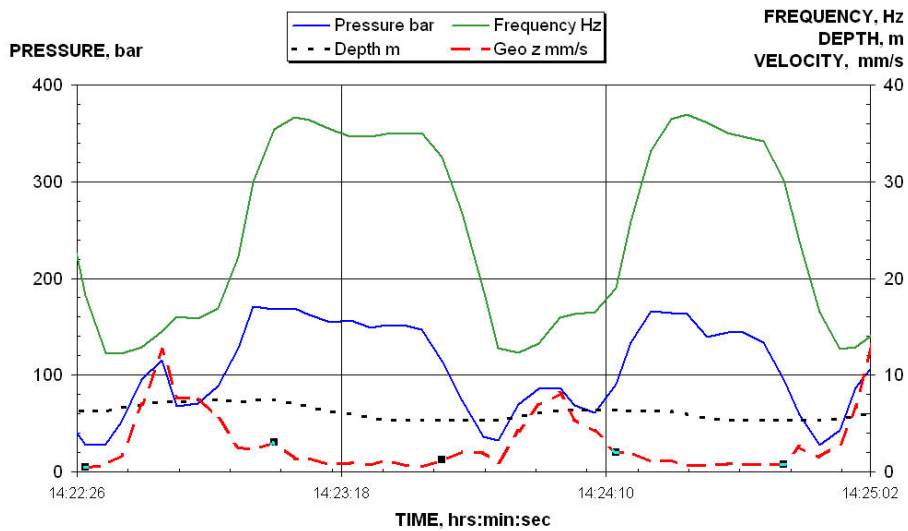

Fig. 10. Vibrator performance during different compaction phases, cf. Fig. 9.

The resonance compaction concept takes advantage of the ground vibration amplification effect, cf. Fig. 3. The compaction process is monitored by an electronic control system, which measures different important vibration parameters continuously (hydraulic pressure, vibration frequency, probe depth, and ground vibration velocity) as a function of time. Figure 11 shows photos from resonance compaction in progress. The

information obtained can be used to evaluate the soil conditions during each compaction pass. This information can be displayed to the machine operator, stored in the computer, and transmitted to the project office for further evaluation.



Fig. 11. Measurement of ground vibrations with the aid of a geophone (foreground) during compaction and monitoring of resonance compaction.

Probe Penetration and Extraction

Deep vibratory compaction is a repetitive process, comprising of three main phases: insertion of the compaction probe to the required depth—densification of the soil—extraction of the compaction probe. The principle steps of the vibratory compaction process using variable frequency are shown in Fig. 12.

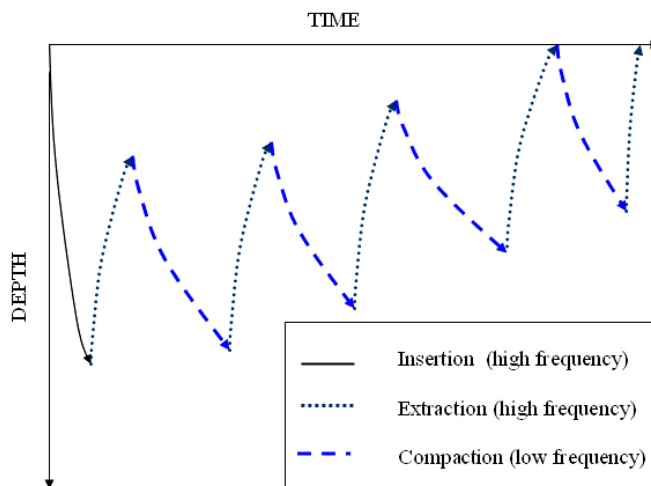

Fig. 12. Principle of deep vibratory compaction using variable frequency concept.

The most efficient compaction process is to insert the probe to the required depth as rapidly as possible at a high vibration frequency, followed by compaction of the soil at (or near to the) resonance frequency and, finally, to extract the probe at high vibration frequency. Compaction will be less efficient if the entire compaction process is carried out at a single frequency. Should a too high frequency be applied, most of the vibration energy will be converted into heat along the probe; and, should the vibration frequency be close to the system resonance frequency, probe penetration will be slow. Moreover, if the probe is extracted at the resonance frequency, the extraction force will be high and the compaction effect is destroyed (decompression). By recording the penetration speed of the compaction probe during insertion at a given vibration frequency, a record of the soil resistance is obtained in each compaction point. At a high vibration frequency, the probe penetration resistance is mainly influenced by the soil resistance at the probe tip. This information can be compared with penetration test results and could serve to provide additional details on the geotechnical conditions of the site. As mentioned above, it is advisable to carry out deep vibratory compaction in two passes. During the second compaction pass, the probe is inserted in the diagonal point of the compaction grid, and the time required for the probe to penetrate the soil layer is again recorded. If the penetration speed at the start of the second compaction pass is the same as during the first pass, the grid spacing was too large. If the penetration speed during the second pass is much lower than during the initial phase, the point spacing was chosen correctly or, possibly, closer than necessary. Thus, the observations at the start of a compaction project or in a special pre-construction test phase can serve to decide on the optimum probe spacing to use. Indeed, deep vibratory compaction equipment can be used as a large-scale soil testing machine for assessing the liquefaction potential of a site.

Duration of Compaction

The duration of compaction in each point is an important parameter and depends on the soil properties prior to compaction, the required degree of densification, and the vibration energy transferred to the ground (intensity and duration). The optimal compaction grid spacing should be determined—at least in the case of larger projects—by compaction trials. As mentioned, in comparing the probe penetration speed during the first and the second compaction pass with penetration tests before and after compaction, the optimal compaction procedure can be established more reliably.

In many cases, the same duration of compaction is applied during the first and second pass. However, it may be advantageous to vary the duration of compaction during the second pass. During the first pass, a uniform compaction procedure should be applied across the entire site. During the second pass, the compaction time should be varied in each point depending on the observed probe penetration speed.

In loose, water-saturated sand deposits, the ground will liquefy during the initial phase of compaction. An example of ground liquefaction is shown in Fig. 13, where the ground water level was approximately 4.5 m below the ground surface. Shortly after densification had started, a zone adjacent to the compaction probe liquefied and ground water rose to the surface. During the liquefaction phase, the ground vibrations almost ceased as no energy was transferred from the probe to the soil. As the sand densified, ground vibrations gradually increased again. During the second compaction pass, liquefaction did not occur. This is an indication that the soil deposit has become more resistant to liquefaction and can be used to verify the design specifications in the case of liquefaction mitigation.



Fig. 13. Liquefaction of water-saturated sand during the initial phase of compaction. Note that the ground water level is 4.5 m below the ground surface.

4. COMPACTION MECHANISM IN SAND

The literature includes only limited information describing the mechanism of soil densification. A few important aspects that affect the compaction mechanism are discussed in the following. For additional information, see Massarsch (2002).

4.1. Transfer of Compaction Energy

A powerful compaction vibrator can generate a centrifugal force of about 1,000 kN to 4,000 kN. In order to achieve optimal soil densification, it is therefore important to use a compaction process where energy is transferred both along the shaft and at the base of the penetrating probe. The most effective energy transfer occurs when the compaction probe is allowed to operate at the resonance frequency. If the probe is kept suspended and vibrated without the full weight of the vibrator and the probe applied to the soil, the compaction effect will be reduced.

4.2. Horizontal ground vibrations

It is often assumed that in the case of a vertically oscillating compaction probe, only vertical ground vibrations are generated. However, horizontal vibrations do occur in addition to vertically polarised shear waves emitted along the shaft of the compaction probe. The horizontal vibrations are caused by the friction between the compaction probe and the soil, and they generate horizontal stress pulses directed away from the probe during the downward movement of the probe. The horizontal stresses give rise to horizontal compression waves which increase the lateral earth pressure. Figure 14 shows the results of vibration measurements during vibratory compaction using the resonance compaction system, Krogh & Lindgren (1997).

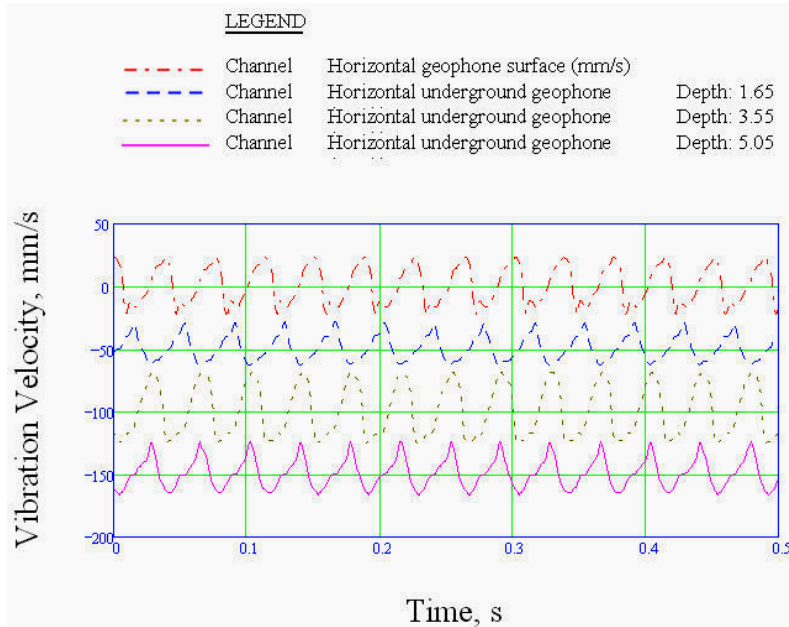

Fig. 14. Horizontal vibration amplitude measured during resonance compaction, from Krogh & Lindgren (1997)

Horizontally oriented vibration sensors (geophones) were installed on, as well at different levels below the ground surface, 2.9 m from the centre of the compaction probe. At the time of the vibration measurements, the tip of the compaction probe was at a depth of 5 m and had thus passed the lowest measuring point. Clearly, the vertically oscillating compaction probe generated strong horizontal vibrations. The probe operated at a vibration frequency of 11 Hz and the frequency of horizontal vibration was 22 Hz (thus twice the vertical vibration frequency). The vibration amplitude in the horizontal and the vertical direction had approximately the same magnitude. As will be shown below, vibratory compaction increases the horizontal stresses in the soil. This compaction effect is of great practical importance as it changes permanently the stress conditions after compaction.

4.3. Increase of Lateral Stresses in Compacted Soil

The mentioned aspect of vibratory compaction - the increase of the lateral stresses in the soil due to vibratory compaction - is not generally appreciated. Sand fill (such as hydraulic fill) is usually normally consolidated prior to compaction, but as a result of vibratory compaction, the lateral earth pressure increases significantly, as shown by Massarsch and Fellenius (2002). The sleeve friction f_s can be approximated from CPT sounding data:

$$f_s = K_0 \sigma'_v \tan(\phi'_a) \quad (0.4)$$

where σ' = effective vertical stress, K_0 = earth pressure coefficient, ϕ'_a = the effective sleeve friction angle at the soil/CPT sleeve interface. The ratio between the sleeve friction after and before compaction, f_{s1}/f_{s0} can be calculated from

$$\frac{f_{s1}}{f_{s0}} = \frac{K_{01} \sigma'_{v1} \tan(\phi'_{a1})}{K_{00} \sigma'_{v0} \tan(\phi'_{a0})} \quad (0.5)$$

where f_{s0} = sleeve friction before compaction, f_{s1} = sleeve friction after compaction, K_{00} = coefficient of earth pressure before compaction (effective stress), K_{01} = coefficient of lateral earth pressure after compaction (effective stress), σ'_{v1} = vertical effective stress before compaction, σ'_{v2} = vertical effective stress after compaction, ϕ'_{a1} = sleeve friction angle before compaction, ϕ'_{a2} = sleeve friction angle after compaction. If it is assumed that the effective vertical stress, σ'_{v1} , is unchanged by the compaction, the ratio of the lateral earth pressure after and before compaction, K_{01}/K_{00} can then be estimated from the relationship according to

$$\frac{K_{01}}{K_{00}} = \frac{f_{s1} \tan(\phi'_{a0})}{f_{s0} \tan(\phi'_{a1})} \quad (0.6)$$

Equation 6 shows that the earth pressure coefficient is directly affected by the change of the sleeve friction and of the friction angle of the soil. The horizontal stresses can vary significantly within the compacted soil. The highest horizontal stresses are expected close to the compaction points and decrease with increasing distance. The initial stress anisotropy initiates a stress redistribution, which can to some extent explain the change of soil strength and of the stiffness with time.

4.4. Overconsolidation Effect

For many geotechnical problems, knowledge of the overconsolidation ratio is important. Empirical relationships have been proposed for the coefficient of lateral earth pressure of normally and overconsolidated sands and for the overconsolidation ratio, OCR,

$$\frac{K_{01}}{K_{00}} = OCR^m \quad (0.7)$$

where K_{00} and K_{01} are the coefficient of lateral earth pressure before and after compaction, respectively and m is an empirically determined parameter. Schmertmann (1985) recommended $m = 0.42$, based on compression chamber tests. Mayne and Kulhawy (1982) suggested $m = 1 - \sin(\phi)$. Jamiolkowski et al (1988) found that the relative density, DR , influences m and that m varied between 0.38 and 0.44 for medium dense sand ($DR = 0.5$). Figure 15 illustrates the relationship from Eq. 7, which shows that even a modest increase of the lateral earth pressure in-creases the overconsolidation ratio significantly.

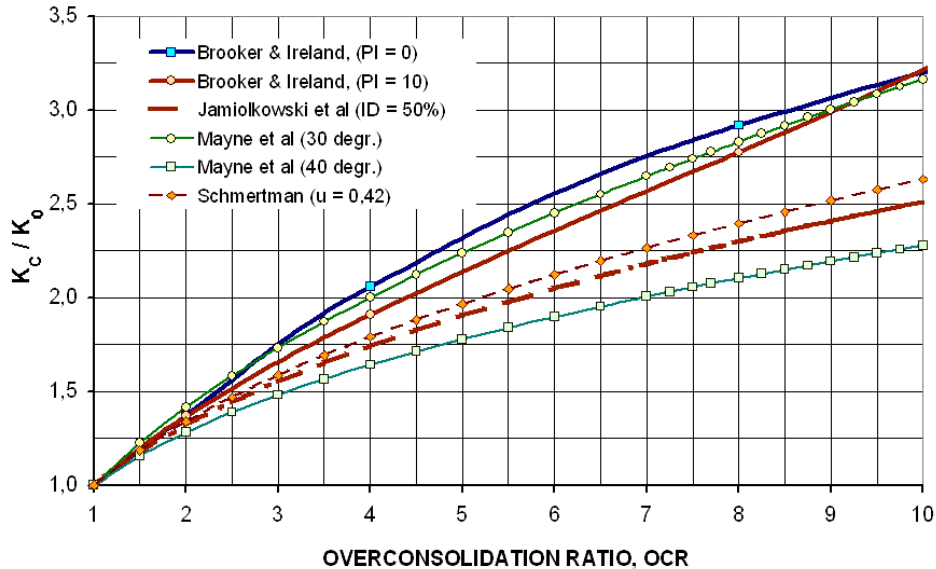

Fig. 15. Relationship between overconsolidation ratio and ratio of earth pressure coefficients for overconsolidated and normally consolidated sand, Fellenius and Massarsch (2001).

Sleeve resistance measurements reported in the literature and the above shown field tests show that the ratio f_{s12}/f_{s01} varies between 1.5 and 3.5, Massarsch and Fellenius (2002). If it is assumed that the effective friction angle increases due to compaction from on average 30 to 36 degrees, K_{01}/K_{00} ranges according to Eq. 6 between 1.2 – 1.8. An average value of $K_{01}/K_{00} = 1.6$ yields an overconsolidation ratio OCR according to Eq. 7 and Fig. 15 in the range of 2.5 – 4.0. This overconsolidation effect, which is generally neglected, is important for the analysis of many geotechnical problems.

4.5. Change of Stress Conditions

The stress conditions in loose, water-saturated sand will undergo a complex change of stress conditions during vibratory compaction. Energy is transmitted from the compaction probe to the surrounding soil at the tip as well as along the sides of the probe. The transmitted vibration energy depends on the capacity of the vibrator, the shear resistance along the probe and on the shape and size of the probe.

At the beginning of compaction of loose, water-saturated sand, the stress conditions will correspond to that of a normally consolidated soil. When the soil is subjected to repeated, high-amplitude vibrations, the pore water pressure will gradually build up and the effective stress is reduced. During the initial phase of compaction, the soil in the vicinity of the compaction probe is likely to liquefy. Whether or not liquefaction will occur, depends on the intensity and duration of vibrations and the rate of dissipation of the excess pore water pressure. If the soil deposit contains layers with low permeability (e. g. silt and clay), these will increase the liquefaction potential. At liquefaction, the effective stresses and thus the shear strength of granular soils are zero.

Although the probe continues to vibrate, the soil will not respond as only little vibration energy can be transmitted from to the soil, cf. Fig. 13. With time, the excess pore water pressure will start to dissipate. The rate of reconsolidation will depend on the permeability of the soil (and interspersed layers).

Figure 16 illustrates the change of effective stresses in a dry granular soil, which is subjected to repeated compaction cycles. During vibratory compaction, high oscillating centrifugal forces (loading and unloading) are generated, that temporarily increase and decrease the vertical and the horizontal effective stress along the compaction probe and at its tip. The initial stresses of the normally consolidated soil correspond to point (A). During the first loading cycle, the stress path follows the K_{00} -line to stress level (B). Unloading to stress level (C) occurs at zero lateral strain and horizontal stresses remain locked in. Each reloading cycle increases the lateral earth pressure, which can reach the passive earth pressure. At the end of compaction, stress point (D) is reached. The vertical overburden pressure is the same after compaction but the horizontal effective stresses have been increased. The lateral earth pressure after compaction can reach the passive value, K_p . Dynamic compaction has thus caused preconsolidation and increased the horizontal effective stress. The increase of the sleeve friction and the high lateral earth pressure can thus be explained by Fig. 16, Fellenius and Massarsch (2001).

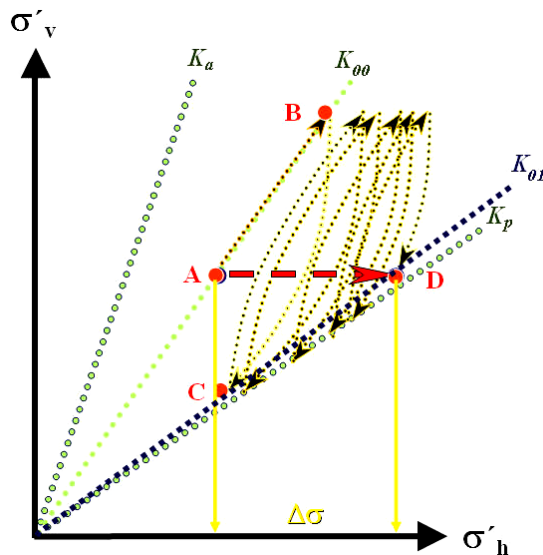

Fig. 16. Stress path of soil in the vicinity of a compaction probe during tow compaction phases; before (A), during first compaction phase (B, C, D and E) and during second compaction phase (E, F, G).

Figure 16 illustrates important aspects of vibratory compaction. The change of the stress conditions from a normally consolidated state to an overconsolidated state is influenced by several factors, such as the compaction method, the state of stress state prior to compaction and the strength and deformation properties of the soil. At resonance compaction, the vertically oscillating probe generates (as a result of friction between the probe and the soil) a high, horizontally oscillating force, which is responsible for the lateral earth pressure in the soil after compaction.

Figure 17 demonstrates the importance of the increase of lateral stresses on the overconsolidation ratio for sand in which the compaction resulted in a friction angle of 36° , improved from values ranging from 21° through 30° before compaction. The sand is assumed to be normally consolidated before compaction with an earth pressure coefficient, K_{00} , equal to 0.5. The CPT measurements provide the sleeve friction values. As discussed above, the ratio of earth pressure coefficients depends primarily on the ratio of sleeve friction and less on the increase in friction angle.

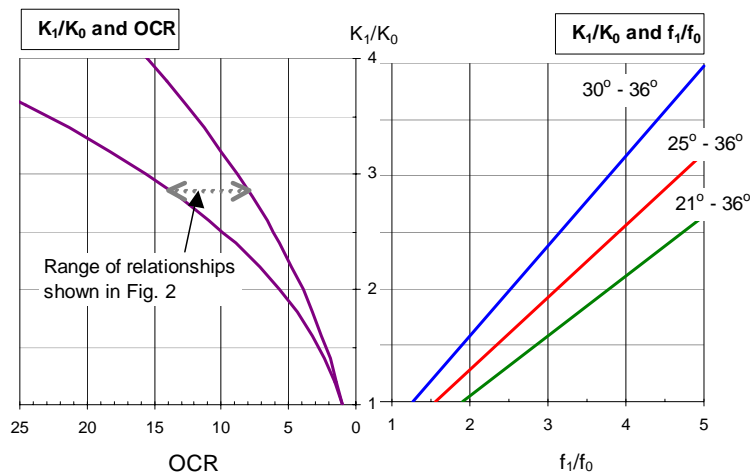

Fig. 17. From ratio between sleeve friction before and after compaction to OCR for three levels of increase of the effective friction angle: 21° to 36° , 25° to 36° , and 30° to 36°

Figure 17 is supplemented with the diagram showing the relation between the earth pressure ratio and the overconsolidation ratio, OCR , introduced by the compaction. The two diagrams suggest that even a moderate increase of sleeve friction will result in a considerable boost of the OCR -value.

4.6. Increase of Soil Strength and Stiffness with Time

Another important factor of soil compaction is the increase of soil strength and stiffness with time after compaction (e.g., Massarsch, 1991; Schmertmann, 1997; Mitchell, 1998). Post-densification CPT results suggest that natural and man-made deposits of clean sand may gain in strength with time after compaction even after the pore pressures induced during compaction have dissipated. The mechanism of this phenomenon is not yet fully understood.

In addition to the complex theories, which have been proposed to explain the change of soil parameters with time after compaction, there may be a rather simple explanation: Due to the heterogeneous stress conditions (horizontal stress variation) in a soil deposit after compaction, a rearrangement of soil particles may take place with time in order to adjust to a more homogeneous stress field. This effect depends on several factors, such as geotechnical conditions, type and execution of compaction process, etc. and is difficult to assess quantitatively without in-situ testing.

5. SUMMARY

Deep vibrocompaction is in spite of its apparent simplicity a rather complex process which requires an active participation of the geotechnical engineer during all phases of the project. However, many vibratory compaction projects are designed and executed without sufficient planning and understanding of the principles, which govern deep soil compaction.

Reliable charts are available to assess the compactability of soils. These are based on results of cone penetration tests, CPT with sleeve friction measurements.

New developments in vibratory compaction have been made possible as a result of more powerful and sophisticated equipment. The use of vibrators with variable frequency and purpose-built compaction probes can enhance the compaction efficiency significantly. Experience from many projects shows that the highest compaction effect is achieved when the soil is compacted at the resonance frequency of the vibrator-probe-soil system. It is recommended to perform compaction in two passes.

Significant benefits in compaction efficiency can be gained from monitoring of the vibratory compaction process. The probe penetration speed at high frequency can be used to establish the geotechnical conditions before compaction and to evaluate the compaction effect.

As a result of vibratory compaction, high lateral stresses are created, which cause a permanent overconsolidation effect. This aspect should be taken into consideration when calculating settlements in vibratory-compacted soils.

6. ACKNOWLEDGEMENTS

The first author wishes to acknowledge the support by the Lisshed Foundation (Lisshed Stiftelsen).

7. REFERENCES

- Eslami, A., and Fellenius, B.H., 1997. Pile capacity by direct CPT and CPTu methods applied to 102 case histories. *Canadian Geotechnical Journal*, Vol. 34, No. 6, pp. 880-898.
- Fellenius, B. H. & Massarsch, K. R., 2001. Deep compaction of coarse-grained soils - A case history. 2001 - A Geotechnical Odyssey: The 54th Annual Canadian Geotechnical Conference. Paper submitted for publication, 8 p.
- Fellenius, B.H., and Eslami, A., 2000. Soil profile interpreted from CPTU data. *Proceedings of the International Conference "Year 2000 Geotechnics"*, Bangkok, November 27-30, 2000.
- Jamiolkowski, M., Ghionna, V. N., Lancelotta R. and Pasqualini, E., (1988). New correlations of penetration tests for design practice. *Proceedings Penetration Testing, ISOPT-1*, DeRuiter (ed.), Balkema, Rotterdam, ISBN 90 6191 801 4, pp 263-296.
- Krogh, P. and Lindgren, A., 1997. Dynamic field measurements during deep compaction at Changi Airport, Singapore, Examensarbete 97/9. Royal Institute of Technology (KTH), Stockholm, Sweden, 88 p.
- Massarsch, K.R., 1991. Deep Soil Compaction Using Vibratory Probes. *American Society for testing and Material, ASTM, Symposium on Design, Construction, and Testing of Deep Foundation Improvement: Stone Columns and Related Techniques*, Robert C. Bachus, Ed. ASTM Special Technical Publication, STP 1089, Philadelphia, pp. 297-319.

- Massarsch, K. R. & Fellenius, B. H., 2001. Vibratory Compaction of Coarse-Grained Soils. *Canadian Geotechnical Journal*, Vol. 39. No. 3, 25 p.
- Massarsch, K. R., 2002. "Effects of Vibratory Compaction". *TransVib 2002 – International Conference on Vibratory Pile Driving and Deep Soil Compaction*. Louvain-la-Neuve. Keynote Lecture, pp. 33 – 42.
- Mayne, P.W. and Kulhawy, F.H. (1982). K_0 -OCR relationship in soil. *ASCE Journal of Geotechnical Engineering*, 108 (6), pp. 851- 870.
- Mitchell, J.K., 1982. Soil improvement-State-of-the-Art, *Proceedings, 10th International Conference on Soil Mechanics and Foundation Engineering, ICSMFE, Stockholm, June, Vol. 4., pp. 509 565.*
- Schlosser, F., 1999. Amélioration et renforcement des sols (Improvement and reinforcement of soils). *4th International Conference on Soil Mechanics and Foundation Engineering, ICSMFE, Hamburg, 1997, Vol. 4, pp. 2445-2466.*
- Schmertmann, J.H., 1985. Measure and use of the in situ lateral stress. *Practice of Foundation Engineering, A Volume Honoring Jorj O. Osterberg*. Edited by R.J. Krizek, C.H. Dowding, and F. Somogyi. Department of Civil Engineering, The Technological Institute, Northwestern University, Evanston, pp. 189-213.